

Case Unit SME_UU

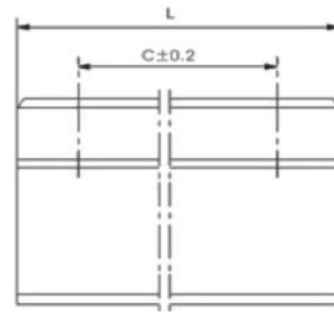
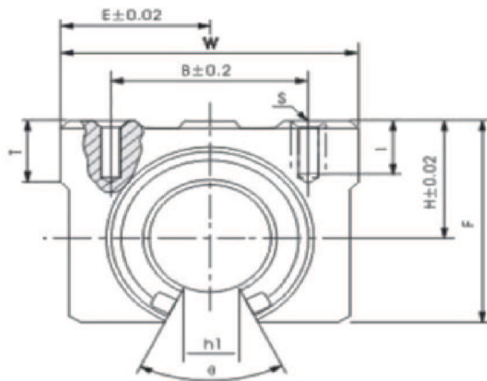

MODEL	SHAFT DIAMETER	MAIN DIMENSIONS								MOUNTING DIMENSIONS				BASIC LOAD RATING		WEIGHT [Kg]
		H	E	W	L	F	T	h1	φ	B	C	S	I	DYNAMIC C[kgf]	STATIC Co[kgf]	
SME10UU	10	15	18	36	32	24	7	6	80°	25	20	M5	10	38	56	0.065
SME12UU	12	17	20	40	39	27.6	8	8.5	80°	28	26	M5	10	42	61	0.1
SME13UU	13	17	20	40	39	27.6	8	8.5	80°	28	26	M5	10	52	80	0.1
SME16UU	16	20	22.5	45	45	33	9	10	80°	32	30	M5	12	59	91	0.15
SME20UU	20	23	24	48	50	39	11	10	60°	35	35	M6	12	88	140	0.2
SME25UU	25	27	30	60	65	47	14	11.5	50°	40	40	M6	12	100	160	0.45
SME30UU	30	33	35	70	70	56	15	14	50°	50	50	M8	18	160	280	0.63
SME35UU	35	37	40	80	80	63	18	16	50°	55	55	M8	18	170	320	0.92
SME40UU	40	42	45	90	90	72	20	19	50°	65	65	M10	20	220	410	1.33
SME50UU	50	53	60	120	110	92	25	23	50°	94	80	M10	20	390	810	3